



1040 8 Ω
1050 16 Ω

M17

PROFESSIONAL SERIES

6.5" Midrange Drivers High Efficiency High Sounding Quality

APPLICATIONS

Mainly designed for sound reinforcement direct radiation multi way systems of small to medium throw (Bandpassed at 500Hz - 4000Hz in a sealed enclosure not exceeding 3L).

Their use in conjunction with a suitable horn allows them to equip long throw systems with a sound quality superior to that produced by any other HF compression chamber.

DESIGN CONCEPT

PROGRESSIVE WAVE DIAPHRAGM optimized for midrange frequency domain. The M17/E17 Series design is based on the PROGRESSIVE WAVE DIAPHRAGM mechanical behavior of the radiating area. In this principle, the membrane is considered as a mechanical transmission line which should receive a constant given velocity together with critical damping properties to work properly.

This leading edge technology offers substantial sonic advantages. Among them : very low mechanical energy storage in the cone (so avoiding standing waves) which ensures coherent sound, fast transients, stable sound imaging, high sensitivity, wide frequency range and very-low directivity pattern.

COMPACT MAGNET SYSTEM. Its design has been optimized to obtain maximum transducing efficiency while avoiding unlinear behavior such as coil inductance variation with position, flux modulation, harmonic distortion, rest position offset, air compression and off-axis voice-coil pushing.

Its design incorporates a T-shaped pole piece, and a flux stabilization ring. It also takes into consideration demagnetization at cold temperatures.

INTERCOOLER SYSTEM (patented). Entirely integrated into the loudspeaker itself, the INTERCOOLER SYSTEM extracts the heat produced by Joule effect in the voice-coil by the means of an air flow directed through the heatsink rims of the basket by the motion of the dust-cap and the spider.

The gain brought about by this technology is over 20 % of extra power, so for example, a 3" coil according to this design has the same power handling capacity as a classical 4" one.



FEATURES

Power handling capacity **160 W AES**
Reference efficiency (1W @ 1m) **100 dB SPL**
SPL max (continuous) **118 dB SPL**
Usable frequency range **500-6000 Hz**
Environmental withstanding **Outdoor**

ARCHITECTURAL SPECIFICATIONS

NOMINAL DIAMETER : 166 mm.

FRAME : High tensile alloy pressure die-cast basket with patented INTERCOOLER SYSTEM.

MAGNET SYSTEM : 1.5" highly energized, heat extracting design with flux stabilizing ring.

VOICE COIL : High-temperature stabilized copper-clad aluminum ribbon wound on vented, high-strength glass polyimide.

CONE ASSEMBLY : High-strength cellulose fiber cone impregnated and front-coated with damped resins, fitted with fabric dome and high-speed flat damped surround.

SPEAKER MASS : 2.15 Kg.

1040 ■ 1050

6.5" Midrange Drivers

1040 1050

TYPICAL CHARACTERISTICS

Rated impedance	Z	8	16	Ω	
Reference efficiency (1 W@1 m)	-	100	100	dB SPL	
Usable frequency range ¹	-	500-6000	500-6000	Hz	
Power handling capacity ² (AES)		160	160	W	
Max Sound Pressure Level ³	SPLmax	118	118	dB SPL	
Min. impedance modulus	Zmin	6.1 @ 750Hz	12.9 @ 750Hz	Ω	
Voice-coil inductance ⁴ @ 1 kHz	Le1k	0.51	1.13	mH	
	@ 10 kHz	Le10k	0.21	0.50	mH
Bl product	Bl	8.9	13.3	N/A	
Moving mass	Mms	0.0070	0.0070	Kg	

THIELE-SMALL PARAMETERS : TYPICAL (QC LIMITS)

Resonance frequency ⁵	Fs	150 (±30)	150 (±30)	Hz
DC resistance ⁶	Re	5.3 (±0.5)	11.6 (±1.1)	Ω
Mechanical quality factor	Qms	4.6	4.6	1
Electrical quality factor	Qes	0.44	0.43	1
Total quality factor	Qts	0.40	0.40	1
Mechanical suspension compliance	Cms	165	165	10 ⁻⁶ m/N
Effective piston area	Sd	0.0150	0.0150	m ²
Equivalent Cas air load	Vas	0.0052	0.0052	m ³
Max. linear excursion	Xmax	±1.0	±1.0	mm
Linear displacement volume	Vd	0.0150	0.0150	10 ⁻³ m ³
Half-space efficiency		3.7	3.8	%
Unity load volume	Vas Qts ²	0.8	0.8	10 ⁻³ m ³

ABSOLUTE MAXIMUM RATINGS

Short term max. input voltage ⁷	Vmax	70	100	V
Max. excursion before damage	Xdam	±2.5	±2.5	mm
Ambient operating temperature		-10 to +50		°C
Storage temperature ⁸		-20 to +70		°C
Environmental conditions ⁹		Outdoor		

APPLICATION INFORMATION

Air volume occupied by the driver ¹⁰		0.46	0.46	10 ⁻³ m ³
Speaker net mass		2.15	2.15	Kg
Recommended reflex box	Vb/Fb	3L / sealed		10 ⁻³ m ³ / Hz
Electrical polarity		A positive voltage applied on the red terminal produces forward cone motion.		

PHYSICAL CHARACTERISTICS

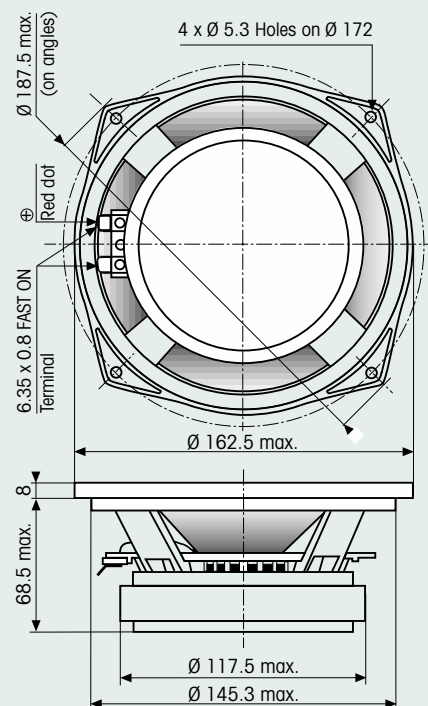

SPECIFICATION NOTES

- Note 1 : Allowing for energy response, excursion capability, Power spectrum, and -3dB low freq. roll-off for standard reflex tuning.
- Note 2 : Established at 20°C ambient temp, according to AES2-1984 standard using IEC268-1 simulated programme signal and a 3 liter sealed test enclosure with a 2nd order high-pass filter @ 800Hz.
- Note 3 : Established at 1m on axis of the loudspeaker mounted in test enclosure, when driven at full AES Power Handling Capacity, including 4dB of thermal compression loss.
- Note 4 : Measured at 20 mA in free air.
- Note 5 : Measured at 20 mA and 20°C ambient temp. in free air conditions, after full run and rest.
- Note 6 : Measured at 20°C ambient temp. QC limits are ±10 %
- Note 7 : Stated in RMS voltage according to IEC 268-5.
- Note 8 : Includes shipping conditions. The lower limit prevents from demagnetization.
- Note 9 : Our products are classified in three categories : Indoor, Outdoor, and Outdoor+ for permanent outdoor use or severe conditions.
- Note 10 : Calculated for front mounting on to a 18 mm thick board.

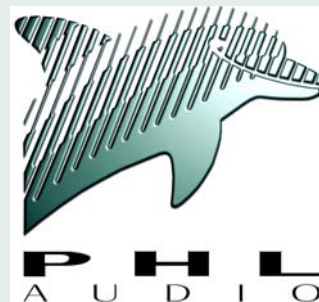

461, rue des chênes .Z.A
77590 CHARTRETTES
FRANCE

Tél : 33 01 64 81 29 80
Fax : 33 01 60 69 10 28

e-mail : phlaudio@phlaudio.com
<http://www.phlaudio.com>