



**1140** 8 Ω  
**1080** 16 Ω

**E17**

**PROFESSIONAL SERIES**

## 6.5" Midrange Extended Drivers High Efficiency Contact Class

### APPLICATIONS

Manufactured up to PHL AUDIO Quality standards, these rugged Contact Class models are cost effective alternatives to models SP1060/1070.

Their application field in sound reinforcement is equivalent, while the compromise is situated in the accuracy of the upper frequencies. SP1140/1080 can be X-overed from as low as 400Hz when single, to 300Hz when used in pairs.

### DESIGN CONCEPT

**PROGRESSIVE WAVE DIAPHRAGM** optimized for low-midrange extended frequency domain.

The M17/E17 Series design is based on the PROGRESSIVE WAVE DIAPHRAGM mechanical behavior of the radiating area.

In this principle, the membrane is considered as a mechanical transmission line which should receive a constant given velocity together with critical damping properties to work properly.

This leading edge technology offers substantial sonic advantages. Among them : very low mechanical energy storage in the cone (so avoiding standing waves) which ensures coherent sound, fast transients, stable sound imaging, high sensitivity, wide frequency range and very-low directivity pattern.

**COMPACT MAGNET SYSTEM.** Its design has been specially optimized to obtain maximum transducing efficiency while avoiding unlinear behavior such as coil inductance variation with position, flux modulation, harmonic distortion, rest position offset, air compression, and off-axis voice-coil pushing.

Its design incorporates a T-shaped pole piece, and a flux stabilization ring. It also takes into consideration demagnetization at cold temperatures.

**INTERCOOLER SYSTEM** (patented). Entirely integrated into the loudspeaker itself, the INTERCOOLER SYSTEM extracts the heat produced by Joule effect in the voice-coil by the means of an air flow directed through the heatsink rims of the basket by the motion of the dust-cap and the spider.

The gain brought about by this technology is over 20 % of extra power, so for example, a 3" coil according to this design has the same power handling capacity as a classical 4" one.



### FEATURES

Power handling capacity **150 W AES**  
Reference efficiency (1W @ 1m) **98 dB SPL**  
SPL max (continuous) **116 dB SPL**  
Usable frequency range **300-5000 Hz**  
Environmental withstanding **Outdoor**

### ARCHITECTURAL SPECIFICATIONS

**NOMINAL DIAMETER** : 166 mm.

**FRAME** : High tensile alloy pressure die-cast basket with patented INTERCOOLER SYSTEM.

**MAGNET SYSTEM** : 1.5" highly energized, heat extracting design with flux stabilizing ring.

**VOICE COIL** : High-temperature stabilized copper wire wound on vented, high-strength glass polyimide.

**CONE ASSEMBLY** : High-strength cellulose fiber cone impregnated and front-coated with damped resins, fitted with fabric dome and high-speed flat damped surround.

**SPEAKER MASS** : 2.15 Kg.

# 1140 ■ 1080

## 6.5" Midrange Extended Drivers

1140      1080

### TYPICAL CHARACTERISTICS

Rated impedance	Z	8	16	Ω	
Reference efficiency (1 W@1 m)	-	98	98	dB SPL	
Usable frequency range <sup>1</sup>	-	300-5000	300-5000	Hz	
Power handling capacity <sup>2</sup> (AES)	-	150	150	W	
Max Sound Pressure Level <sup>3</sup>	SPLmax	116	116	dB SPL	
Min. impedance modulus	Zmin	6.8 @ 650 Hz	12.6 @ 650 Hz	Ω	
Voice-coil inductance <sup>4</sup> @ 1 kHz	Le1k	0.69	1.09	mH	
	@ 10 kHz	Le10k	0.30	0.47	mH
Bl product	Bl	10.5	12.7	N/A	
Moving mass	Mms	0.0085	0.0085	Kg	

### THIELE-SMALL PARAMETERS : TYPICAL (QC LIMITS)

Resonance frequency <sup>5</sup>	Fs	130 (±25)	130 (±25)	Hz
DC resistance <sup>6</sup>	Re	6.1 (±0.6)	11.3 (±1.1)	Ω
Mechanical quality factor	Qms	6.3	6.6	1
Electrical quality factor	Qes	0.38	0.49	1
Total quality factor	Qts	0.36	0.45	1
Mechanical suspension compliance	Cms	180	180	10 <sup>-6</sup> m/N
Effective piston area	Sd	0.0150	0.0150	m <sup>2</sup>
Equivalent Cas air load	Vas	0.0056	0.0056	m <sup>3</sup>
Max. linear excursion	Xmax	±2.0	±2.0	mm
Linear displacement volume	Vd	0.030	0.030	10 <sup>-3</sup> m <sup>3</sup>
Half-space efficiency		3.0	2.4	%
Unity load volume	Vas Qts <sup>2</sup>	0.7	1.1	10 <sup>-3</sup> m <sup>3</sup>

### ABSOLUTE MAXIMUM RATINGS

Short term max. input voltage <sup>7</sup>	Vmax	70	95	V
Max. excursion before damage	Xdam	4.0	4.0	mm
Ambient operating temperature		-10 to +50		°C
Storage temperature <sup>8</sup>		-20 to +70		°C
Environmental conditions <sup>9</sup>		Outdoor		

### APPLICATION INFORMATION

Air volume occupied by the driver <sup>10</sup>		0.46	0.46	10 <sup>-3</sup> m <sup>3</sup>
Speaker net mass		2.15	2.15	Kg
Recommended reflex box	Vb/Fb	3L / sealed		L / Hz
Electrical polarity		A positive voltage applied on the red terminal produces forward cone motion.		

### PHYSICAL CHARACTERISTICS

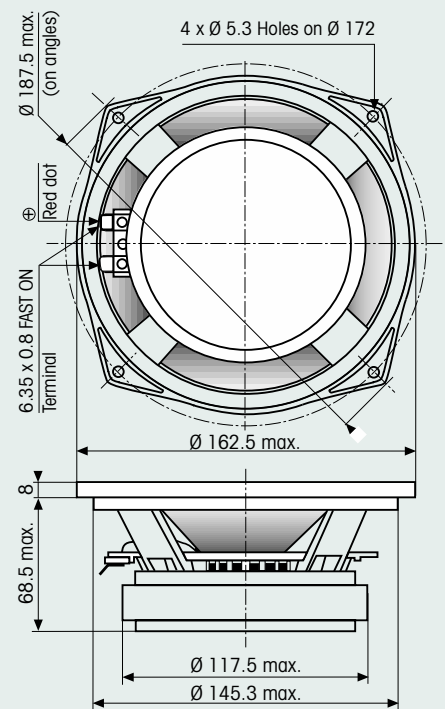

### SPECIFICATION NOTES

- Note 1 : Allowing for energy response, excursion capability, Power spectrum, and -3dB low freq. roll-off for standard reflex tuning.
- Note 2 : Established at 20°C ambient temp, according to AES2-1984 standard using IEC268-1 simulated programme signal and a 3 liter sealed test enclosure with a 2nd order high-pass filter @ 400Hz.
- Note 3 : Established at 1m on axis of the loudspeaker mounted in test enclosure, when driven at full AES Power Handling Capacity, including 4dB of thermal compression loss.
- Note 4 : Measured at 20 mA in free air.
- Note 5 : Measured at 20 mA and 20°C ambient temp. in free air conditions, after full run and rest.
- Note 6 : Measured at 20°C ambient temp. QC limits are ±10 %
- Note 7 : Stated in RMS voltage according to IEC 268-5.
- Note 8 : Includes shipping conditions. The lower limit prevents from demagnetization.
- Note 9 : Our products are classified in three categories : Indoor, Outdoor, and Outdoor+ for permanent outdoor use or severe conditions.
- Note 10 : Calculated for front mounting on to a 18 mm thick board.



461, rue des chênes .Z.A  
77590 CHARTRETTES  
FRANCE

Tél : 33 01 64 81 29 80  
Fax : 33 01 60 69 10 28

e-mail : phaudio@phaudio.com  
http://www.phaudio.com