



1500 8 Ω
1510 16 Ω

M17

PROFESSIONAL SERIES

6.5" Midrange Driver Very High Sound Pressure Level High Sounding Quality

APPLICATIONS

These models are an excellent alternative to types SP1040/1050 when very high SPL are needed in sound reinforcement. Sound transcription is of utmost accuracy due to the mastery of the diaphragm behavior even at full level, which allows for their use in studio monitoring too. Direct radiation within frequency band 400Hz - 4000 Hz, in a sealed volume not exceeding 3L is possible while use with a horn loaded for high power systems is its real destination.

DESIGN CONCEPT

PROGRESSIVE WAVE DIAPHRAGM optimized for midrange frequency domain. The M17/E17 Series design is based on the PROGRESSIVE WAVE DIAPHRAGM mechanical behavior of the radiating area. In this principle, the membrane is considered as a mechanical transmission line which should receive a constant given velocity together with critical damping properties to work properly.

This leading edge technology offers substantial sonic advantages. Among them: coherent sound, fast transients, stable sound imaging, high sensitivity, wide frequency range and reduced directivity pattern.

VENTED COMPACT MAGNET SYSTEM. Its has been carefully optimized to obtain maximum transducing efficiency while avoiding unlinear behavior such as coil inductance variation with position, flux modulation, harmonic distortion, rest position offset, air compression, and off-axis voice-coil pushing.

Its design incorporates a T-shaped and vented pole piece, and a flux stabilization ring. It also takes into consideration demagnetization at cold temperatures.

INTERCOOLER SYSTEM (patented). Entirely integrated into the loudspeaker itself, the INTERCOOLER SYSTEM extracts the heat produced by Joule effect in the voice-coil by the means of an air flow directed through the heatsink rims of the basket by the motion of the dust-cap and the spider.

The gain brought about by this technology is over 20 % of extra power, so for example, a 3" coil according to this design has the same power handling capacity as a classical 4" one.

FERROFLUID COOLING The FERROFLUID COOLING Proceeding consists in replacing the voice-coil air clearance in the air-gap by a stable magnetic fluid which offers far better thermal conductivity, allowing the driver to withstand an extra amount of power of short to medium duration with less risk of coil overheating than in the unferrofluid design. Improving short term reliability, the main advantage of FERROFLUID COOLING is its thermal compression reducing effect which can reach 3dB at high power. Nevertheless, no improvement of the operating life duration is to be expected.



FEATURES

Power handling capacity **250 W AES**
Reference efficiency (1W @ 1m) **98 dB SPL**
SPL max (continuous) **119 dB SPL**
Usable frequency range **400-5000 Hz**
Environmental withstanding **Outdoor+**

ARCHITECTURAL SPECIFICATIONS

NOMINAL DIAMETER : 166 mm.

FRAME : High tensile alloy pressure die-cast basket with patented INTERCOOLER SYSTEM.

MAGNET SYSTEM : 2" highly energized, heat extracting design with vented pole piece and flux stabilizing ring.

VOICE COIL : High-temperature stabilized, FERROFLUID®-cooled copper-clad aluminum ribbon wound on vented high-strength glass polyamide former.

CONE ASSEMBLY : High-strength cellulose fiber cone impregnated and coated on both sides with damped resins, fitted with central carbon-fiber dome, high-speed flat damped surround and acoustically damped rear cavity.

SPEAKER MASS : 2.60 Kg.

1500 ■ 1510

6.5" Midrange Drivers

1500 1510

TYPICAL CHARACTERISTICS

Rated impedance	Z	8	16	Ω
Reference efficiency (1 W@1 m)	-	98	98	dB SPL
Usable frequency range ¹	-	400-5000	400-5000	Hz
Power handling capacity ² (AES)	-	250	250	W
Max Sound Pressure Level ³	SPL _{max}	119	119	dB SPL
Min. impedance modulus	Z _{min}	6.2 @ 650Hz	12 @ 600Hz	Ω
Voice-coil inductance ⁴ @ 1 kHz	L _{e1k}	0.58	1.14	mH
	@ 10 kHz	L _{e10k}	0.30	0.60
Bl product	Bl	11.0	15.8	N/A
Moving mass	M _{ms}	0.0105	0.0105	Kg

THIELE-SMALL PARAMETERS : TYPICAL (QC LIMITS)

Resonance frequency ⁵	F _s	130 (±25)	130 (±25)	Hz
DC resistance ⁶	R _e	5.5 (±0.6)	10.6 (±1.1)	Ω
Mechanical quality factor	Q _{ms}	4.1	4.1	1
Electrical quality factor	Q _{es}	0.39	0.37	1
Total quality factor	Q _{ts}	0.36	0.34	1
Mechanical suspension compliance	C _{ms}	145	145	10 ⁻⁶ m/N
Effective piston area	S _d	0.0150	0.0150	m ²
Equivalent C _{as} air load	V _{as}	0.0045	0.0045	m ³
Max. linear excursion	X _{max}	±1.0	±1.0	mm
Linear displacement volume	V _d	0.0150	0.0150	10 ⁻³ m ³
Half-space efficiency		2.4	2.6	%
Unity load volume	V _{as} Q _{ts} ²	0.6	0.5	10 ⁻³ m ³

ABSOLUTE MAXIMUM RATINGS

Short term max. input voltage ⁷	V _{max}	90	125	V
Max. excursion before damage	X _{dam}	±2.5	±2.5	mm
Ambient operating temperature		-10 to +50		°C
Storage temperature ⁸		-20 to +70		°C
Environmental conditions ⁹		Outdoor+		

APPLICATION INFORMATION

Air volume occupied by the driver ¹⁰		0.64	0.64	10 ⁻³ m ³
Speaker net mass		2.60	2.60	Kg
Recommended reflex box	V _b /F _b	3L / sealed		L / Hz
Electrical polarity		A positive voltage applied on the red terminal produces forward cone motion.		

PHYSICAL CHARACTERISTICS

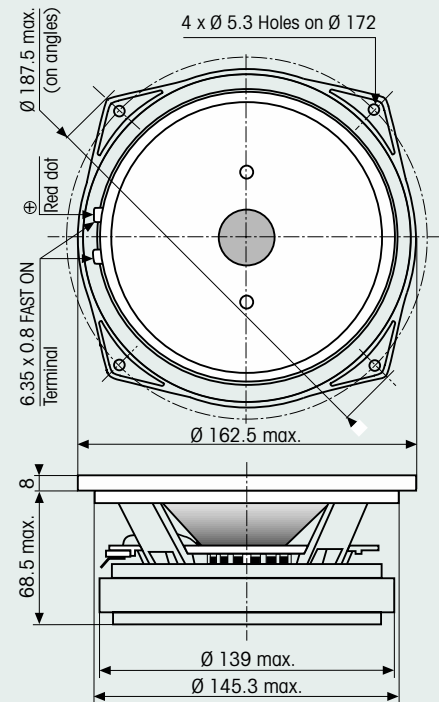

SPECIFICATION NOTES

- Note 1 : Allowing for energy response, excursion capability, Power spectrum, and -3dB low freq. roll-off for standard reflex tuning.
- Note 2 : Established at 20°C ambient temp, according to AES2-1984 standard using IEC268-1 simulated programme signal and a 3 liter sealed test enclosure with a 2nd order high-pass filter @ 800Hz.
- Note 3 : Established at 1m on axis of the loudspeaker mounted in test enclosure, when driven at full AES Power Handling Capacity, including 3dB of thermal compression loss.
- Note 4 : Measured at 20 mA in free air.
- Note 5 : Measured at 20 mA and 20°C ambient temp. in free air conditions, after full run and rest.
- Note 6 : Measured at 20°C ambient temp. QC limits are ±10 %
- Note 7 : Stated in RMS voltage according to IEC 268-5.
- Note 8 : Includes shipping conditions. The lower limit prevents from demagnetization.
- Note 9 : Our products are classified in three categories : Indoor, Outdoor, and Outdoor+ for permanent outdoor use or severe conditions.
- Note 10 : Calculated for front mounting on to a 18 mm thick board.



461, rue des chênes . Z.A
77590 CHARTRETTES
FRANCE

Tél : 33 01 64 81 29 80
Fax : 33 01 60 69 10 28

e-mail : phludio@phludio.com
<http://www.phludio.com>